

EPLAN-CAE		DESCRIPTION P&ID PROCESS		This document contains confidential and proprietary information of STERIS Corporation. Neither this document nor the information therein are to be reproduced, distributed, used or disclosed either in part or in whole except as specifically authorized by STERIS Corporation.		NAME (See PLM Signature History Record)		DATE		TITLE RELIANCE 300XLs		
1	2	3	4	5	6	7	8	9	10	1	D	
							DRAWING NUMBER 10227392		VERSION A		SHEET 1 OF 10	

208V 60HZ

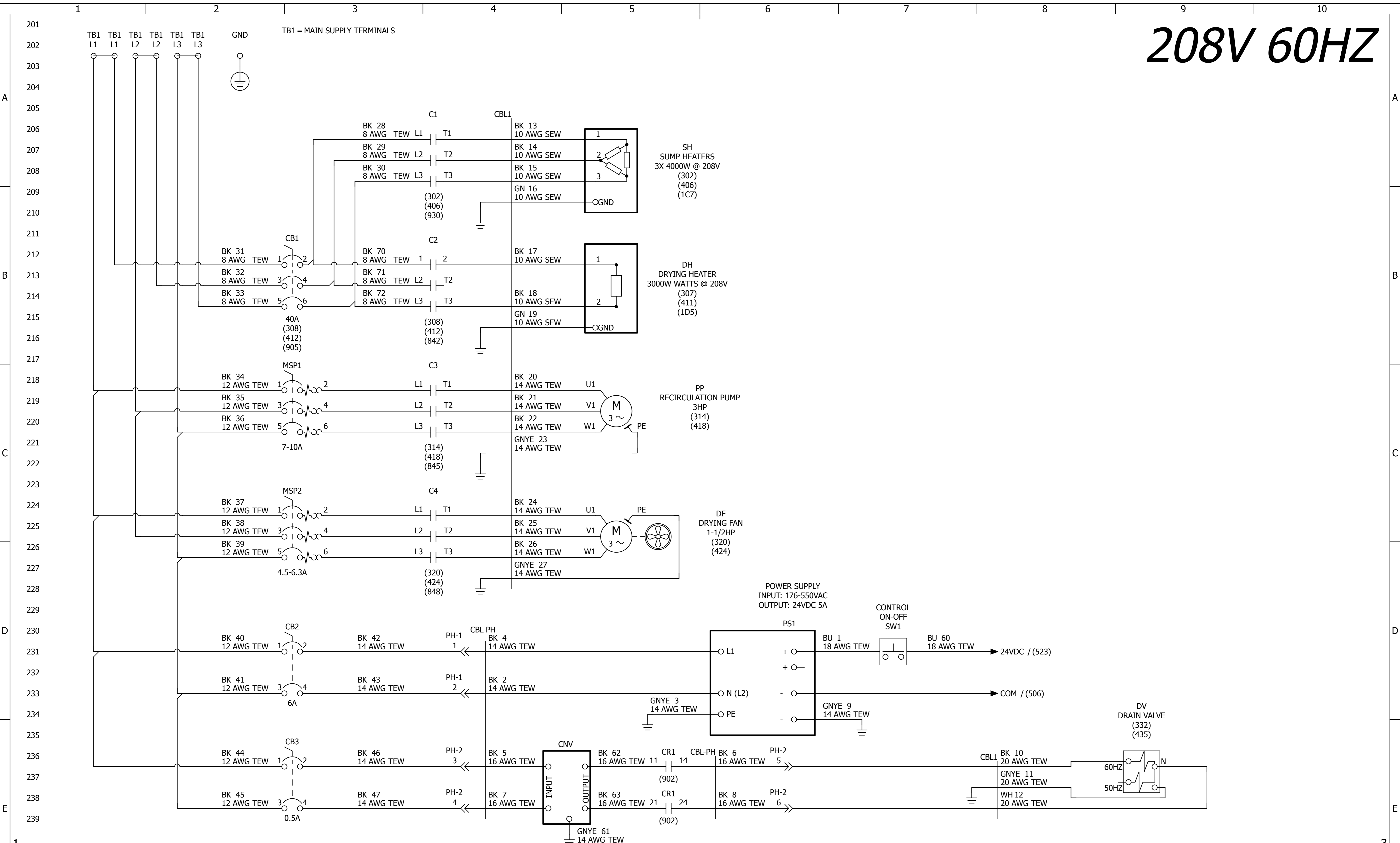

DESCRIPTION
ELECTRICAL SCHEMATIC
 MAIN SUPPLY
 208VAC 60HZ



This document contains confidential and proprietary information of STERIS Corporation. Neither this document nor the information therein are to be reproduced, distributed, used or disclosed either in part or in whole except as specifically authorized by STERIS Corporation.

APPROVER
 REVIEWER
 DRAWN BY

NAME
(See PLM Signature History Record)

DATE

TITLE
RELIANCE 300XLS

LOCATION	SCALE 1	SIZE D	DRAWING NUMBER 10227392	VERSION A	SHEET 2 OF 10
----------	------------	-----------	----------------------------	--------------	------------------

460-480V 60HZ

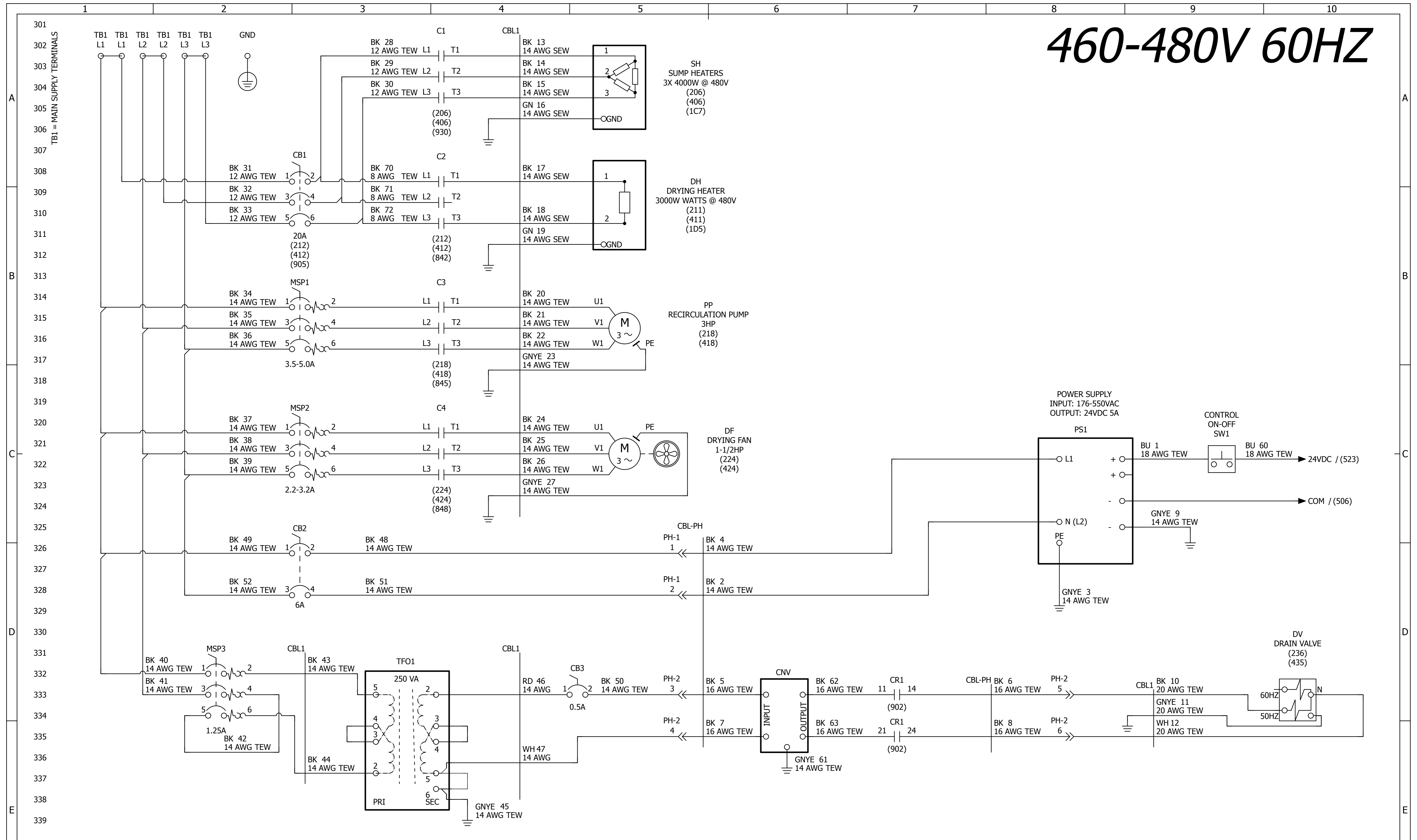

DESCRIPTION
ELECTRICAL SCHEMATIC
 MAIN SUPPLY
 480VAC 60HZ

STERIS
 This document contains confidential and proprietary information of STERIS Corporation. Neither this document nor the information therein are to be reproduced, distributed, used or disclosed either in part or in whole except as specifically authorized by STERIS Corporation.

APPROVER	NAME	DATE
REVIEWER	(See PLM Signature History Record)	
DRAWN BY		

TITLE	RELIANCE 300XLS				
LOCATION	SCALE	SIZE	DRAWING NUMBER	VERSION	SHEET
	1	D	10227392	A	3 OF 10

380-400-415V 50HZ

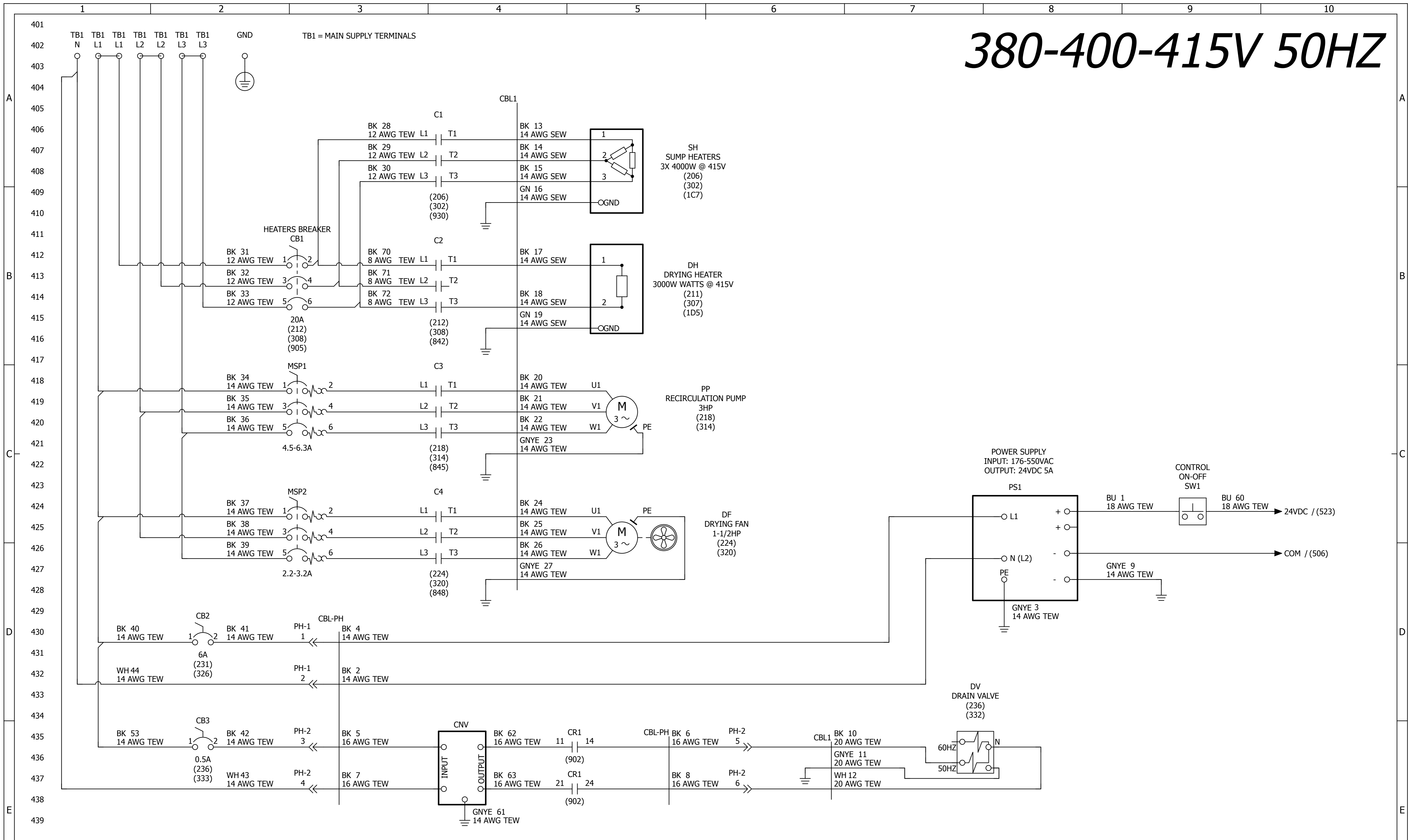

DESCRIPTION
ELECTRICAL SCHEMATIC
 MAIN SUPPLY
 380-400-415VAC 50HZ 380-400VAC 60HZ

STERIS
 STERIS Corporation
 This document contains confidential and proprietary information of STERIS Corporation. Neither this document nor the information therein are to be reproduced, distributed, used or disclosed either in part or in whole except as specifically authorized by STERIS Corporation.

APPROVER
 REVIEWER
 DRAWN BY
 NAME
 (See PLM Signature History Record)
 DATE

TITLE
RELIANCE 300XLS
 LOCATION
 SCALE
 1
 SIZE
 D
 DRAWING NUMBER
 10227392
 VERSION
 A
 SHEET
 4 OF 10

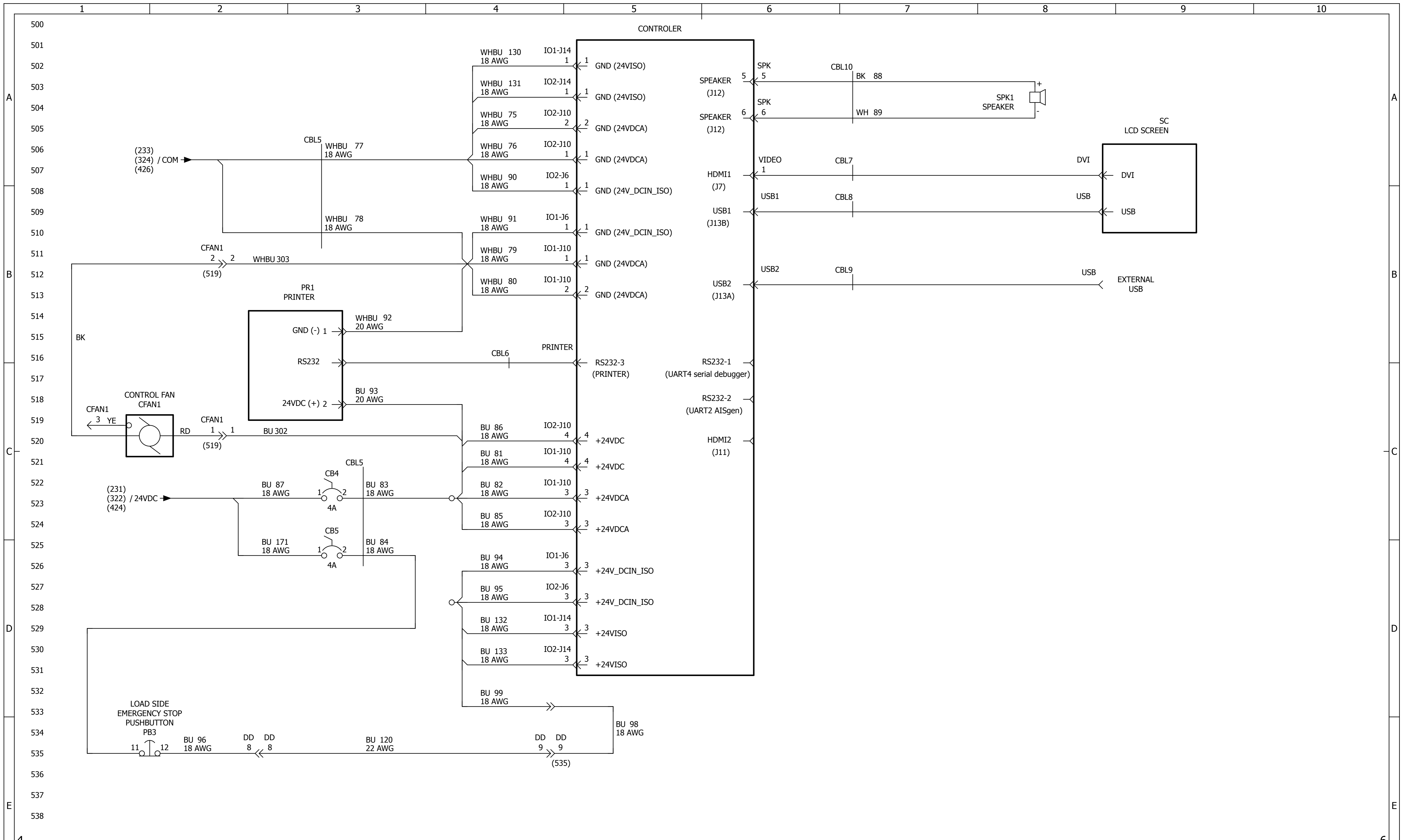

DESCRIPTION
ELECTRICAL SCHEMATIC
 CONTROLLER/DISPLAY/PRINTER

STERIS
This document contains confidential and proprietary information of STERIS Corporation. Neither this document nor the information therein are to be reproduced, distributed, used or disclosed either in part or in whole except as specifically authorized by STERIS Corporation.

APPROVER	NAME	DATE
REVIEWER	(See PLM Signature History Record)	
DRAWN BY		

TITLE RELIANCE 300XL5				
LOCATION	SCALE	SIZE	DRAWING NUMBER	VERSION
	1	D	10227392	A
SHEET			5 OF 10	

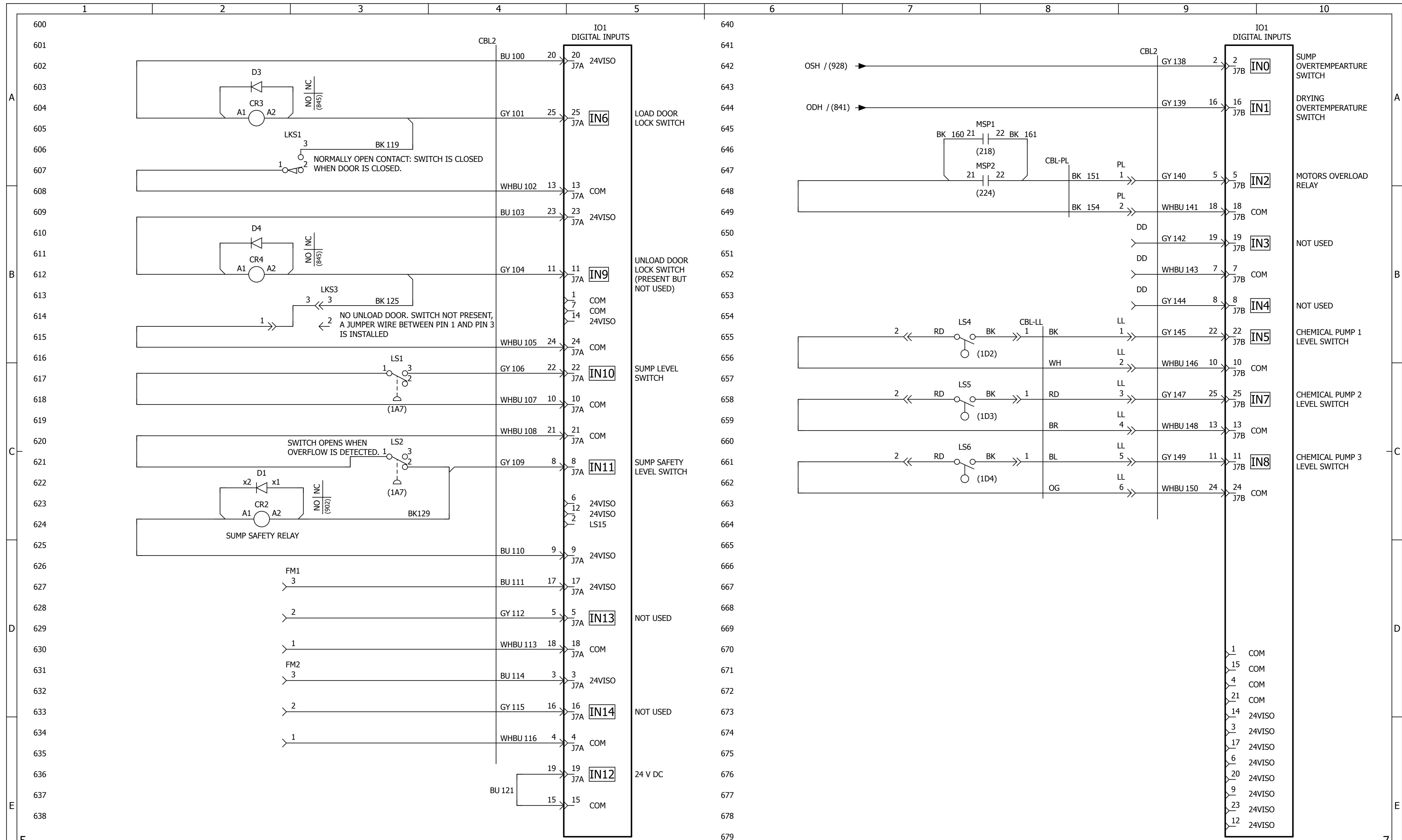

DESCRIPTION
ELECTRICAL SCHEMATIC
IO BOARD #1 (INPUT)

STERIS
This document contains confidential and proprietary information of STERIS Corporation. Neither this document nor the information therein are to be reproduced, distributed, used or disclosed either in part or in whole except as specifically authorized by STERIS Corporation.

APPROVER	NAME	DATE
REVIEWER	(See PLM Signature History Record)	
DRAWN BY		

TITLE RELIANCE 300XLS				
LOCATION	SCALE	SIZE	DRAWING NUMBER	VERSION
	1	D	10227392	A
				SHEET
				6 OF 10

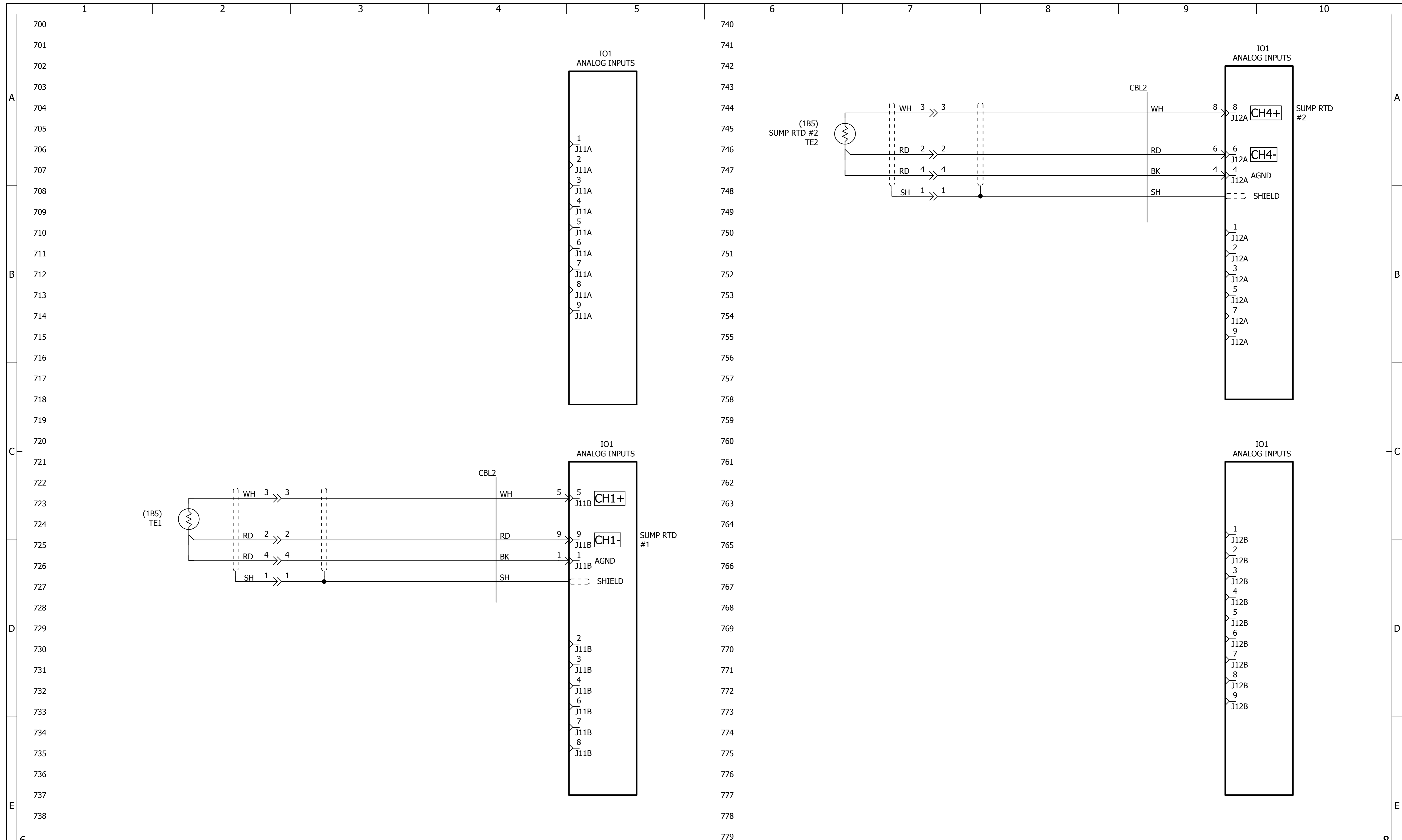

DESCRIPTION
ELECTRICAL SCHEMATIC
 IO BOARD #1 (ANALOG INPUT)

STERIS
This document contains confidential and proprietary information of STERIS Corporation. Neither this document nor the information therein are to be reproduced, distributed, used or disclosed either in part or in whole except as specifically authorized by STERIS Corporation.

APPROVER
 REVIEWER
 DRAWN BY

NAME
(See PLM Signature History Record)

DATE

TITLE
RELIANCE 300XLS

LOCATION	SCALE 1	SIZE D	DRAWING NUMBER 10227392	VERSION A	SHEET 7 OF 10
----------	------------	-----------	----------------------------	--------------	------------------

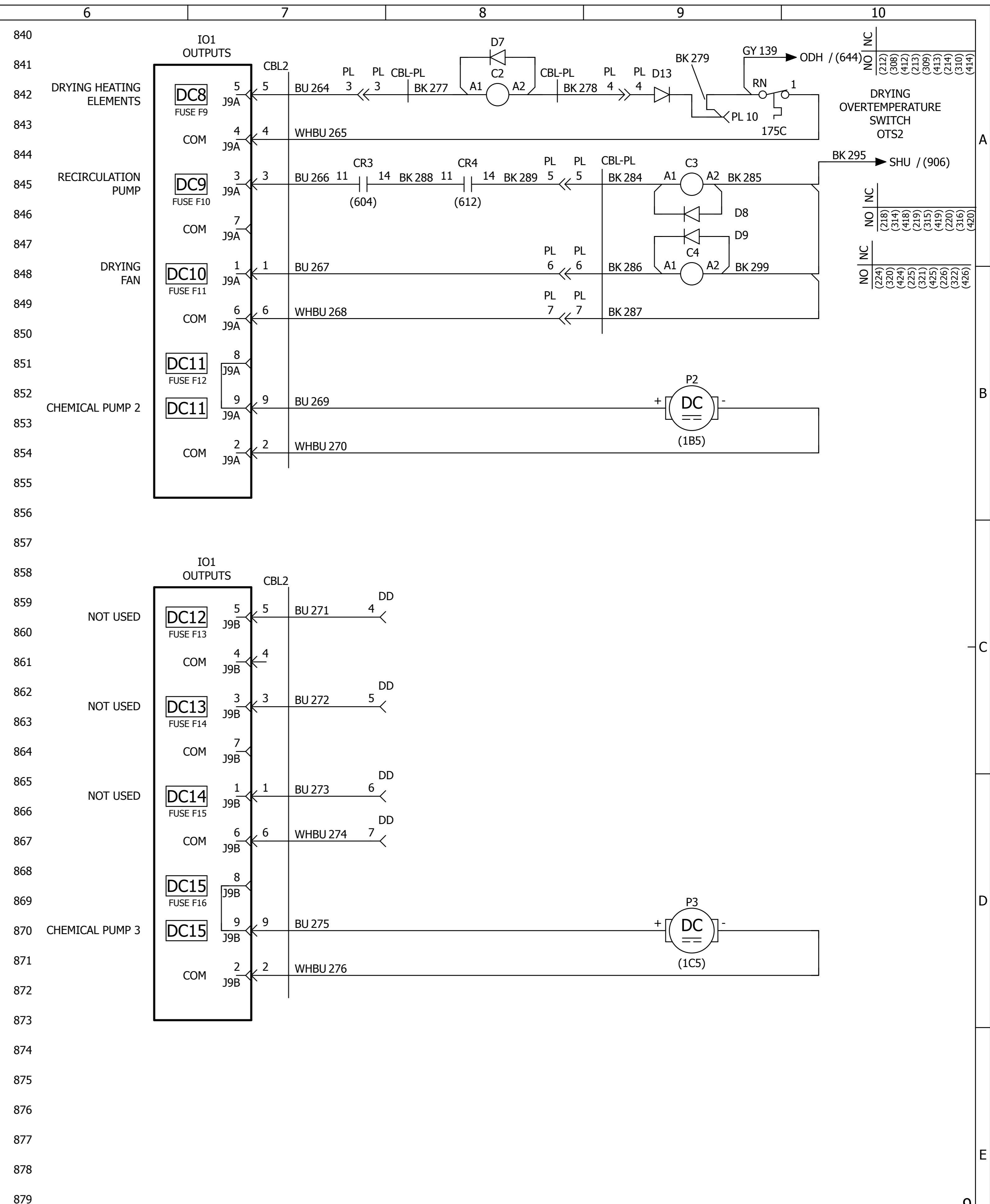
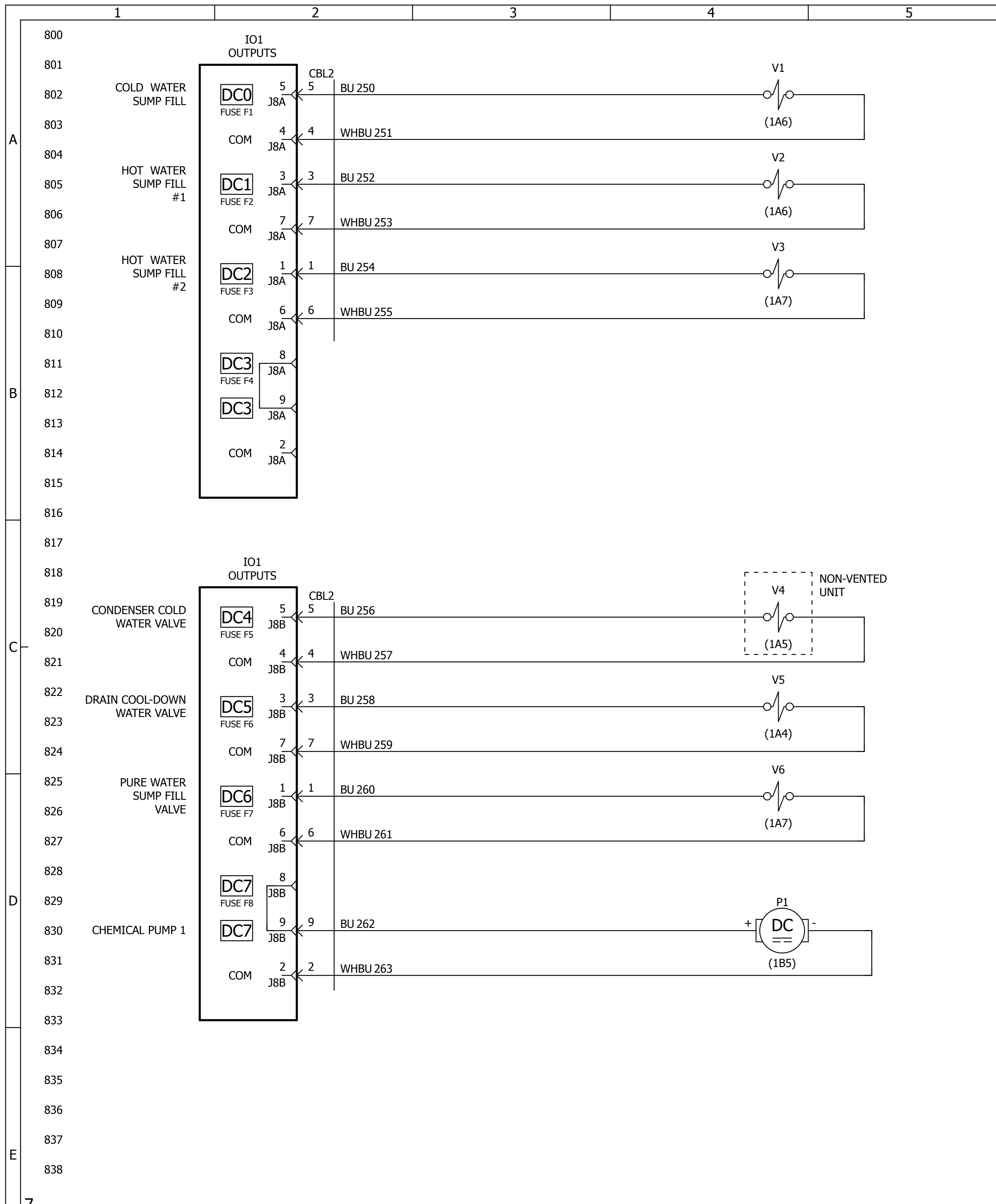

DESCRIPTION
ELECTRICAL SCHEMATIC
 IO BOARD #1 (OUTPUT)

STERIS
 This document contains confidential and proprietary information of STERIS Corporation. Neither this document nor the information therein are to be reproduced, distributed, used or disclosed either in part or in whole except as specifically authorized by STERIS Corporation.

APPROVER
 REVIEWER
 DRAWN BY

NAME
 (See PLM Signature History Record)

DATE

TITLE
RELIANCE 300XL5

LOCATION	SCALE 1	SIZE D	DRAWING NUMBER 10227392	VERSION A	SHEET 8 OF 10
----------	------------	-----------	----------------------------	--------------	------------------

